

## Model for XPC-independent Transcription-coupled Repair of Pyrimidine Dimers in Humans\*

(Received for publication, December 26, 1996)

David Mu‡ and Aziz Sancar§

From the Department of Biochemistry and Biophysics,  
School of Medicine, CB 7260, University of North  
Carolina, Chapel Hill, North Carolina 27599-7260

**In humans, DNA lesions such as pyrimidine dimers in the template strand of genes transcribed by RNA polymerase II are repaired faster than those in the coding strand and nontranscribed regions of the genome. This phenomenon, referred to as transcription-coupled repair (i) requires active transcription, (ii) does not require the XPC gene product which is essential for general/basal repair reactions, and (iii) requires the CSA and CSB proteins. We have developed an *in vitro* model system that consists of purified human excision repair factors and a DNA substrate analogous to a transcription bubble terminating at a cyclobutane thymine dimer. In this system the thymine dimer was excised independent of XPC. Furthermore, the thymine dimer in the bubble-containing substrate was removed approximately 3-fold faster by the excision repair nuclease reconstituted with or without XPC, compared with the removal of thymine dimer from a base paired duplex by the entire set of excision nuclease factors. These results provide important insight into the mechanism of transcription-coupled repair in humans.**

Nucleotide excision repair is an important cellular defense mechanism that repairs almost all types of DNA damages and is the sole human cellular tool against bulky DNA adducts. In the majority of organisms, ultraviolet (UV) light-induced cyclobutane pyrimidine dimers and bulky adducts formed by a variety of carcinogens are repaired preferentially in the sequences that are undergoing active transcription (1–3). Both in *Escherichia coli* and in humans the mechanistic basis of transcription-coupled repair (also termed preferential repair) appears to be the faster repair rate of the transcribed (template) strand than the nontranscribed (coding) strand (2, 3). Nucleotide excision repair, which is the only repair system in human cells that repairs bulky DNA lesions (4–6), and transcription by the cognate polymerase are two essential constituents of transcription-coupled repair. In addition, studies in *E. coli* (7) and humans (*cf.* Ref. 8 and references therein) have revealed

that another factor called transcription repair coupling factor is also essential for transcription-repair coupling. In *E. coli*, the transcription repair coupling factor is encoded by the *mfd* gene (9). Biochemical experiments have established that the *mfd* gene product in combination with the bacterial excision repair nuclease consisting of three polypeptides, UvrA, UvrB, and UvrC, are necessary and sufficient for carrying out transcription-coupled repair *in vitro* (10).

In humans, transcription-coupled repair is dependent on Cockayne syndrome complementation group A (CSA)<sup>1</sup> and Cockayne syndrome complementation group B (CSB) proteins which may function as coupling factors (8, 11, 12). Even though the bacterial transcription-coupled repair has been reconstituted *in vitro* and investigated in some detail (13, 14), the mechanism of transcription-dependent repair in humans is not known for lack of an *in vitro* system. In fact, some doubt has been expressed as to whether transcription-coupled repair, in the sense of faster repair of a lesion in a ternary complex with stalled RNA polymerase II, operates in human cells (15). The main difficulty in reconstituting human transcription-stimulated repair in an *in vitro* system stems from the fact that RNA polymerase II-directed transcription *in vitro* is inefficient, typically resulting in 1–10% template utilization (16, 17). The low efficiency transcription combined with 2–20% of damage excision for a typical *in vitro* repair reaction (5, 6) makes it quite difficult to detect transcription-dependent repair signal.

Since a pivotal intermediate in models for transcription-coupled repair, based on data that show excision of damage without displacement of RNA polymerase II, is a transcription bubble stalled at a lesion (18, 35), we decided to construct a substrate mimicking that structure of DNA and subject it to excision repair in a defined system. It is thought that the catalytic center of RNA polymerase in a stalled complex is within 2 base pairs of the lesion and that the unwinding does not extend more than 1–2 base pairs ahead of the catalytic site (19, 20). Furthermore, the transcription bubble has been determined to be  $17 \pm 5$  nucleotides in *E. coli* and 10–11 nucleotides in mammalian cells (21, 22). Hence, to generate an artificial transcription bubble stalled at a lesion, we designed a substrate with 10 mispaired base pairs in a row in the immediate 3' side of a cyclobutane thymine dimer (T<>T). When this substrate was subjected to the human excision nuclease of defined composition, surprisingly it was found that one of its basal constituents, the XPC protein, is not needed for damage excision to occur. Furthermore, a photodimer next to a bubble is excised faster than one in a normal duplex. Collectively, these results provide important insights into the mechanism of transcription-coupled repair.

### MATERIALS AND METHODS

**DNA Substrate Preparations**—The preparation of T<>T(0) was as reported previously (23–25). Substrate T<>T(3'–10) was prepared by phosphorylating oligomer 5 (Table I) using [ $\gamma$ -<sup>32</sup>P]ATP (7000 Ci/mmol, ICN) and T4 polynucleotide kinase, followed by annealing and ligation with oligonucleotides 1, 2, and a fourth oligomer of 24 nucleotides (5'-TGGCGCTCCATAATACTCAGGGTG-3'). The single-stranded 136-mer (1-5-2) was isolated using an 8% denaturing polyacrylamide gel.

\* This work was supported in part by National Institutes of Grant GM32388. The costs of publication of this article were defrayed in part by the payment of page charges. This article must therefore be hereby marked "advertisement" in accordance with 18 U.S.C. Section 1734 solely to indicate this fact.

‡ Supported by a postdoctoral fellowship (Grant DRG-1319) from the Cancer Research Fund of the Damon Runyon Walter Winchell Foundation, New York.

§ To whom correspondence should be addressed: Dept. of Biochemistry and Biophysics, School of Medicine, CB 7260, University of North Carolina, Chapel Hill NC 27599-7260. Tel.: 919-962-0115; Fax: 919-966-2852.

<sup>1</sup> The abbreviations used are: CS, Cockayne syndrome; XP, xeroderma pigmentosum; ERCC, excision repair cross-complementing; RPA, replication protein A; TFIIH, transcription factor II H; T<>T, cyclobutane thymine dimer.

TABLE I  
Oligonucleotides (5' to 3') used to assemble substrates in this study

Oligonucleotide 5 contains a cyclobutane thymine dimer denoted T<>T. Mismatched nucleotides in oligonucleotide 7 are underlined.

Oligonucleotide #	Nucleotide sequence
1	CGGACCTGAACAGTACGGAAATTCGATATCCTCGAGCCAGATCTGCGCCAGCTGGCCACCCTGA
2	GAGCGCCAAGCTGGGCTGCAGCAGGTCGACTCTAGAGGATCCCGGGCGAGCTCGAATTCGCCC
3	GGTGGCCAGCTGGCGCAGATCTGGCTCGAGGATATCGAATTCGTTACGTGTTTCAGGTCC
4	GGGGCGAATTCGAGCTCGCCCGGGATCCTCTAGAGTCGACCTGCTGCAGCCCAAGCTTGGC
5	GTAT<>TATG
6	GCTCCATAATACTCAG
7	GGGGCGAATTCGAGCTCGCCCGGGATCCTCTAGAGTCGACCTGCTGC AGCCAAGCTTGC <u>CGC</u> GAGGTATATACTCAGGGTGGCCAGCTGGCGCA GATCTGGCTCGAGGATATCGAATTCCTACGTGTTTCAGGTCC

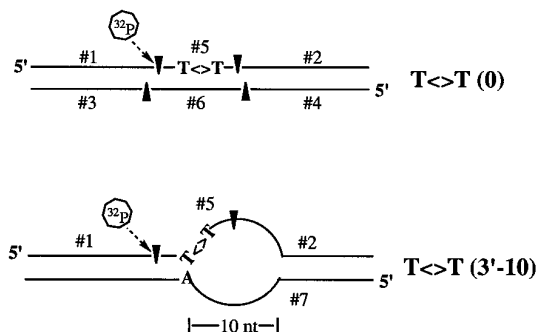

FIG. 1. **Substrate constructs used in this study.** The two T<>T-containing substrates are indicated as T<>T(0) and T<>T(3'-10). The oligonucleotides used to assemble both substrates are indicated by a # sign, and their nucleotide sequences are listed in Table I. T<>T-containing oligonucleotide #5 was prepared following the procedure of Smith and Taylor (33). Both substrates were internally radiolabeled at the fourth phosphodiester bond 5' to the photodimer.

This single-stranded 136-mer containing a T<>T was annealed with a 136-mer (oligonucleotide 7) and purified using a 5% nondenaturing polyacrylamide gel.

**DNA Damage Excision Reactions and Repair Factors**—Excision reactions were conducted as described previously (23, 25). Figs. 2 and Fig. 3B show the autoradiograms of the denaturing polyacrylamide gels (8%) bearing the resolved excision reaction mixtures. Repair factors were purified as described previously (25).

## RESULTS AND DISCUSSION

In *E. coli* both transcription-coupled and general excision repair require the participation of the whole bacterial excision repair nuclease which consists of UvrA, UvrB, and UvrC proteins (5). In humans, general excision repair depends on coordinated action of 14 polypeptides (5, 6), including those encoded by the xeroderma pigmentosum (XP) genes (XPA, XPB, XPC, XPD, XPF, and XPG). Quite interestingly, in contrast to the bacterial system, in humans one of the basal repair nuclease factors, the XPC protein, is not required for transcription-coupled excision repair (26–28). Assuming that our model substrate T<>T(3'-10) (Fig. 1) imitates the events occurring during transcription-coupled repair, is XPC then not required for the repair of a thymine dimer with a neighboring bubble?

Since we have recently reconstituted the excision repair nuclease *in vitro* (23, 25), we were in a position to examine this question directly. We carried out repair reactions using the reconstituted repair system consisting of six basal repair factors including proteins encoded by the XP genes. These six repair factors are XPA, RPA, TFIIH, XPC, XPF-ERCC1, and XPG (23, 25). As shown in Fig. 2, amazingly, the XPC protein is not required for excision of the thymine dimer in the pseudotranscription bubble substrate (Fig. 2, lane 9). This provides a plausible answer to the long-standing enigma as to why XPC is not involved in transcription-coupled repair and strongly suggests that the lesion-stalled transcription bubble plays an important role in transcription-coupled repair in humans. While

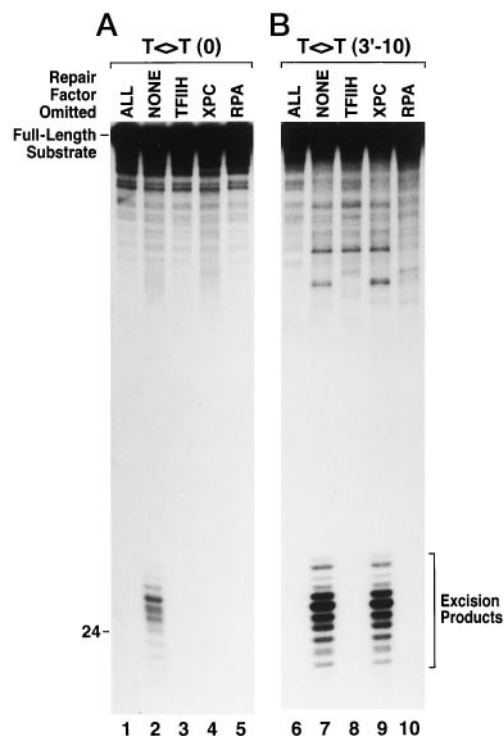
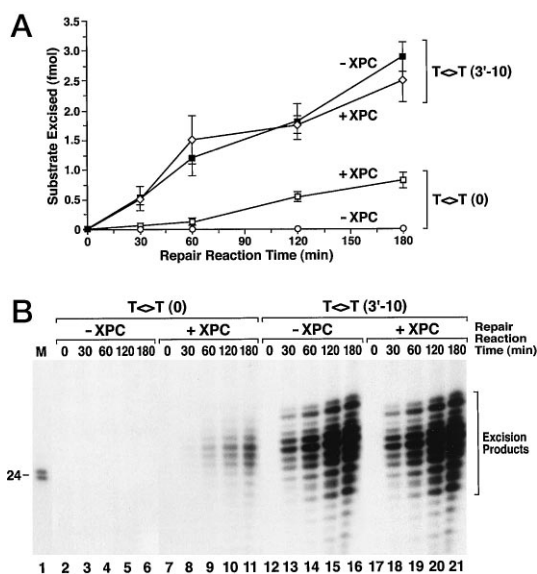

FIG. 2. **XPC is not needed for repair of T<>T with a neighboring 3' pseudotranscription bubble.** Internally radiolabeled duplex substrate T<>T(0) (A) and substrate T<>T(3'-10) (B) were incubated with the entire set of six repair factors or in mixtures with the indicated omissions. Note that both the XPC and the human homolog B of Rad23 (HHR23B) proteins were omitted in lanes 4 and 9. XPC and HHR23B form a heterodimer as demonstrated by Masutani *et al.* (31). The repair reaction conditions were as described by Mu *et al.* (25), and the reactions were carried out for 3 h at 30 °C. The bands in the 24–32-nucleotide region generated by the dual incision activity of the human excision nuclease (5). The bands seen with the bubble substrate, T<>T(3'-10), in the upper part of the autoradiogram in lanes 7, 8, and 9 presumably arose from the junction cutting activities of XPG and XPF-ERCC1; these junction-cutting activities are stimulated by RPA (24).

no excision can be detected from base paired duplex substrate in the absence of XPC (lane 4), the level of thymine dimer excised from the bubble substrate was comparable with and without XPC (compare lanes 7 and 9). Importantly, the XPC-independent repair activity was totally dependent on all of the other five constituents of excision nuclease (lanes 8 and 10 and data not shown), indicating that this activity is genuine to the excision repair nuclease.

Fig. 2 indicates, in a qualitative manner, that a T<>T adjacent to a bubble is repaired more efficiently than a T<>T in a base paired duplex. We reasoned that if this repair imitated transcription-coupled repair, the T<>T adjacent to a bubble should be excised at a faster rate than a T<>T in a base-paired duplex. Hence, a kinetic experiment was conducted using the



**FIG. 3. Pseudotranscription bubble enhances the repair rate of cyclobutane thymine dimer.** Internally radiolabeled substrates (20 fmol), T<=>T(0) or T<=>T(3'-10), were mixed with either the six basal excision nuclease factors (+XPC) or with five factors only (-XPC) and incubated at 30 °C for various periods of time as indicated (B). The repair signals (*i.e.* the damage-containing excision products) were quantified using a PhosphorImager (Molecular Dynamics), and the results are plotted in A. Bars indicate standard error of two experiments.

two substrates, pseudotranscription bubble (T<=>T(3'-10)) and normal duplex (T<=>T(0)), with the idea of T<=>T(3'-10) and T<=>T(0) being representatives of lesions in transcribed and nontranscribed DNA, respectively. Fig. 3 shows that the thymine dimer next to a pseudotranscription bubble was repaired at an approximately 3-fold faster rate than the dimer in duplex DNA, in line with the preferential repair rate of transcribed strand over nontranscribed strand *in vivo* (2, 3). Elimination of the T<=>T by photoreactivation abolished excision from the pseudotranscription bubble substrate (data not shown), indicating that what we are observing is true damage excision and not release of a fragment by the combined action of XPG and XPF-ERCC1 junction-cutting nuclease activities (5, 6). In addition, the kinetics of T<=>T excision for the bubble substrate was nearly identical in the presence and absence of XPC, whereas excision from the duplex was completely XPC-dependent, consistent with the *in vivo* data on preferential repair in humans (26–28).

In conclusion, we believe we have developed a model system for human transcription-coupled excision repair. This mode of nucleotide excision repair has three unique features: (i) it is restricted to the transcription blocked by lesions in the template strand, (ii) it is independent of XPC, and (iii) it requires the CSA and CSB proteins. Our system encompasses the first two features but is independent of CSA (29) and CSB (30) proteins. The results are also consistent with the recent finding that a pyrimidine dimer blocking the progress of RNA polymerase II can be excised by the human excision repair nuclease system without displacing RNA polymerase II (35). In fact, the two studies combined point to transcription bubble as a necessary intermediate in transcription-coupled repair in humans. Indeed, we have found that a synthetic DNA substrate containing a cholesterol moiety substituted for a nucleoside can be excised by the reconstituted excision nuclease in the absence of XPC from a nominally duplex DNA (25). It is quite likely that the cholesterol substitution causes significant unwinding in the immediate vicinity of the lesion and generates a transcription bubble-like structure. Based on this observation, and on the

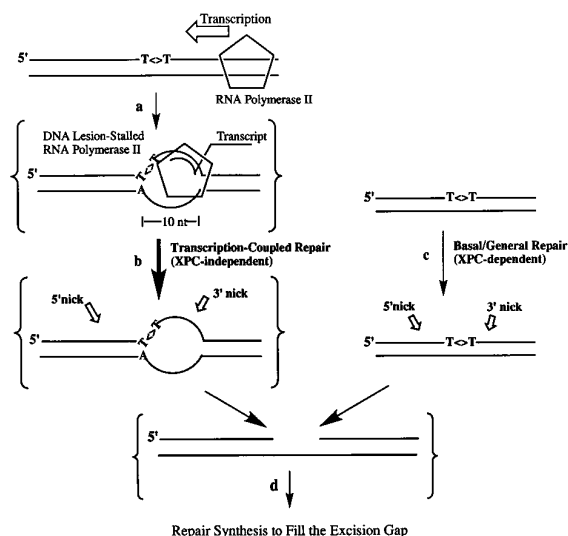

**FIG. 4. Model for transcription-coupled repair in humans.** A thymine dimer (T<=>T) in the template strand impedes the progression of RNA polymerase II as demonstrated by Donahue *et al.* (34) (step a), resulting in a stalled transcription bubble neighboring the 3'-thymine of the photodimer. The repair of T<=>T in this intermediate takes place without displacing the stalled RNA polymerase II<sup>2</sup> and without the assistance of XPC (step b) (for simplicity and because of many unanswered questions regarding the interactions of CSA and CSB with RNA polymerase II and repair factors, details surrounding step b have been omitted), giving rise to the intermediate containing a single-stranded gap of approximately 30 nucleotides. The general (basal) excision repair nuclease recognizes T<=>T and excises an oligonucleotide containing the lesion (step c) in a XPC-dependent manner. The observation that step b occurs faster than step c constitutes transcription-coupled repair. The resulting single-stranded gap is filled by resynthesis to give the fully repaired DNA (step d).

biochemical properties of XPC, which include high affinity for single-stranded DNA (31, 32), we previously hypothesized that XPC stabilizes an unwound DNA intermediate in general (transcription-independent) repair reaction (25). Together with data presented in this study, it appears that during transcription-coupled repair a stable bubble terminating at a lesion exists and that such an intermediate obviates the need of XPC in the excision reaction.

However, it must be noted that our system does not mimic transcription-coupled repair in its entirety. It is known that CSA and CSB proteins are also essential for coupled repair (4–6). The precise roles of these proteins are not known at present. Recent data indicate that CSB enables the access of excision repair factors to the transcription bubble by specific interactions with stalled RNA polymerase II without disrupting the transcription bubble (35). A model consistent with existing data is presented in Fig. 4. Future work with a stalled RNA polymerase II and CSA plus CSB proteins should provide a more detailed model for transcription repair coupling in humans.

**Acknowledgments**—Dr. X. Zhao is acknowledged for supplying the T<=>T-containing oligonucleotide. We thank Drs. T. Bessho, J. T. Reardon, and C. P. Selby for comments on this manuscript.

#### REFERENCES

- Bohr, V. A., Smith, C. A., Okumoto, D. S., and Hanawalt, P. C. (1985) *Cell* **40**, 359–369
- Mellon, I., Spivak, G., and Hanawalt, P. C. (1987) *Cell* **51**, 241–249
- Mellon, I., and Hanawalt, P. C. (1989) *Nature* **342**, 95–98
- Friedberg, E. C., Walker, G. C., and Siede, W. (1995) *DNA Repair and Mutagenesis*, ASM Press, Washington, D. C.
- Sancar, A. (1996) *Annu. Rev. Biochem.* **65**, 43–81
- Wood, R. D. (1996) *Annu. Rev. Biochem.* **65**, 135–167
- Selby, C. P., and Sancar, A. (1991) *Proc. Natl. Acad. Sci. U. S. A.* **88**, 8232–8236
- Friedberg, E. C. (1996) *Annu. Rev. Biochem.* **65**, 15–42
- Selby, C. P., Witkin, E. M., and Sancar, A. (1991) *Proc. Natl. Acad. Sci. U. S. A.*

- 88, 11574–11578
10. Selby, C. P., and Sancar, A. (1993) *Science* **260**, 53–58
  11. Hanawalt, P. C. (1994) *Science* **266**, 1957–1958
  12. Hanawalt, P. C., Donahue, B. A., and Sweder, K. S. (1994) *Curr. Biol.* **4**, 518–521
  13. Selby, C. P., and Sancar, A. (1995) *J. Biol. Chem.* **270**, 4882–4889
  14. Selby, C. P., and Sancar, A. (1995) *J. Biol. Chem.* **270**, 4890–4895
  15. Friedberg, E. C. (1996) *BioEssay* **18**, 731–738
  16. Conaway, R. C., and Conaway, J. W. (1993) *Annu. Rev. Biochem.* **62**, 161–190
  17. Zawel, L., and Reinberg, D. (1995) *Annu. Rev. Biochem.* **64**, 533–561
  18. Selby, C. P., and Sancar, A. (1997) *J. Biol. Chem.* **272**, 1885–1890
  19. Shi, Y.-B., Gamper, H., van Houten, B., and Hearst, J. E. (1988) *J. Mol. Biol.* **199**, 277–293
  20. Kainz, M., and Roberts, J. (1992) *Science* **255**, 838–841
  21. Gamper, H., and Hearst, J. E. (1982) *Cell* **29**, 81–90
  22. Gamper, H., and Hearst, J. E. (1983) *Cold Spring Harbor Symp. Quant. Biol.* **47**, 455–461
  23. Mu, D., Park, C.-H., Matsunaga, T., Hsu, D., Reardon, J. T., and Sancar, A. (1995) *J. Biol. Chem.* **270**, 2415–2419
  24. Matsunaga, T., Park, C.-H., Bessho, T., Mu, D., and Sancar, A. (1996) *J. Biol. Chem.* **271**, 11047–11050
  25. Mu, D., Hsu, D., and Sancar, A. (1996) *J. Biol. Chem.* **271**, 8285–8294
  26. Venema, J., van Hoffen, A., Natarajan, A. T., van Zeeland, A. A., and Mullenders, L. H. F. (1990) *Nucleic Acids Res.* **18**, 443–448
  27. Venema, J., van Hoffen, A., Karcagi, V., Natarajan, A. T., van Zeeland, A. A., and Mullenders, L. H. F. (1991) *Mol. Cell. Biol.* **11**, 4128–4134
  28. van Hoffen, A., Venema, J., Meschini, R., van Zeeland, A. A., and Mullenders, L. H. F. (1995) *EMBO J.* **14**, 360–367
  29. Henning, K. A., Li, L., Iyer, N., McDaniel, L. D., Reagan, M. S., Legerski, R., Schultz, R. A., Stefanini, M., Lehmann, A. R., Mayne, L. V., and Friedberg, E. C. (1995) *Cell* **82**, 555–564
  30. Troelstra, C., van Gool, A., de Wit, J., Vermeulen, W., Bootsma, D., and Hoeijmakers, J. H. J. (1992) *Cell* **71**, 939–953
  31. Masutani, C., Sugawara, K., Yanagisawa, J., Sonoyama, T., Ui, M., Enomoto, T., Takio, K., Tanaka, K., van der Spek, P. J., Bootsma, D., Hoeijmakers, J. H. J., and Hanaoka, F. (1994) *EMBO J.* **13**, 1831–1843
  32. Reardon, J. T., Mu, D., and Sancar, A. (1996) *J. Biol. Chem.* **271**, 19451–19456
  33. Smith, C. A., and Taylor, J.-S. (1993) *J. Biol. Chem.* **268**, 11143–11151
  34. Donahue, B., Yin, S., Taylor, J.-S., Reines, D., and Hanawalt, P. C. (1994) *Proc. Natl. Acad. Sci. U. S. A.* **91**, 8502–8506
  35. Selby, C. P., Drapkin, R., Reinberg, D., and Sancar, A. (1997) *Nucleic Acids Res.* **25**, 787–793